

# Lecture 21

## Frequency Response of Amplifiers (I)

### Common-Emitter Amplifier

#### Outline

- Review frequency domain analysis
- BJT and MOSFET models for frequency response
- Frequency Response of Intrinsic Common-Emitter Amplifier
- Effect of transistor parameters on  $f_T$

#### **Reading Assignment:**

Howe and Sodini, Chapter 10, Sections 10.1-10.4

# I. Frequency Response Review

## Phasor Analysis of the Low-Pass Filter

- Example:

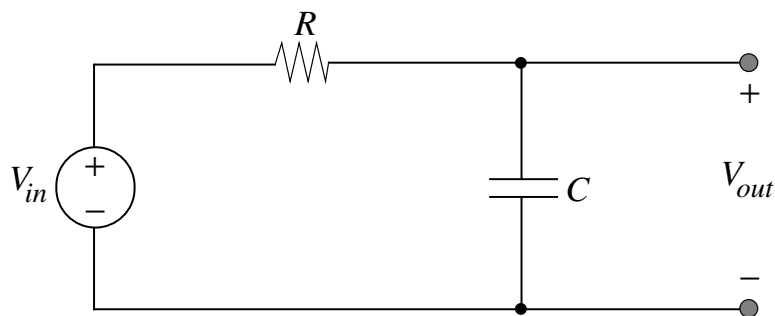

- Replacing the capacitor by its impedance,  $1 / (j\omega C)$ , we can solve for the ratio of the phasors  $V_{out}/V_{in}$

$$\frac{V_{out}}{V_{in}} = \frac{1 / j\omega C}{R + 1 / j\omega C}$$

$$\frac{V_{out}}{V_{in}} = \frac{1}{1 + j\omega RC}$$

- $V_{out} \equiv$  Phasor notation

## Magnitude Plot of LPF

- $\left| V_{out} / V_{in} \right| \rightarrow 1$  for “low” frequencies
- $\left| V_{out} / V_{in} \right| \rightarrow 0$  for “high” frequencies

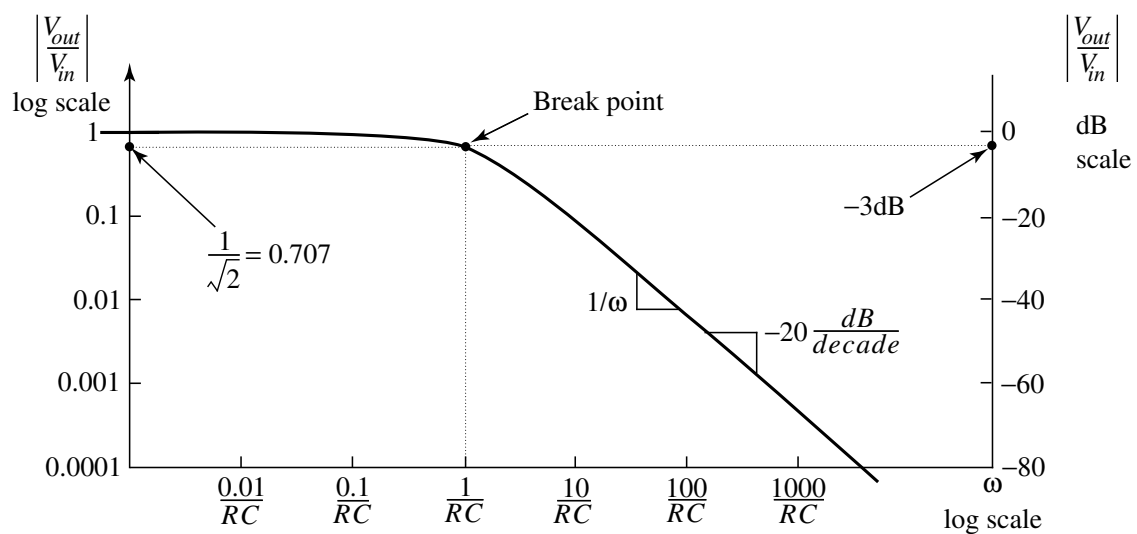

- The “break point” is when the frequency is equal to  $\omega_0 = 1 / RC$
- The break frequency defines “low” and “high” frequencies.
- $\text{dB} \equiv 20 \log x \rightarrow 20\text{dB} = 10, 40\text{dB} = 100, -40\text{dB} = .01$
- At  $\omega_0$  the ratio of phasors has a magnitude of  $-3 \text{ dB}$ .

# Phase Plot of LPF

- Phase ( $V_{out} / V_{in}$ ) =  $0^\circ$  for low frequencies
- Phase ( $V_{out} / V_{in}$ ) =  $-90^\circ$  high frequencies.

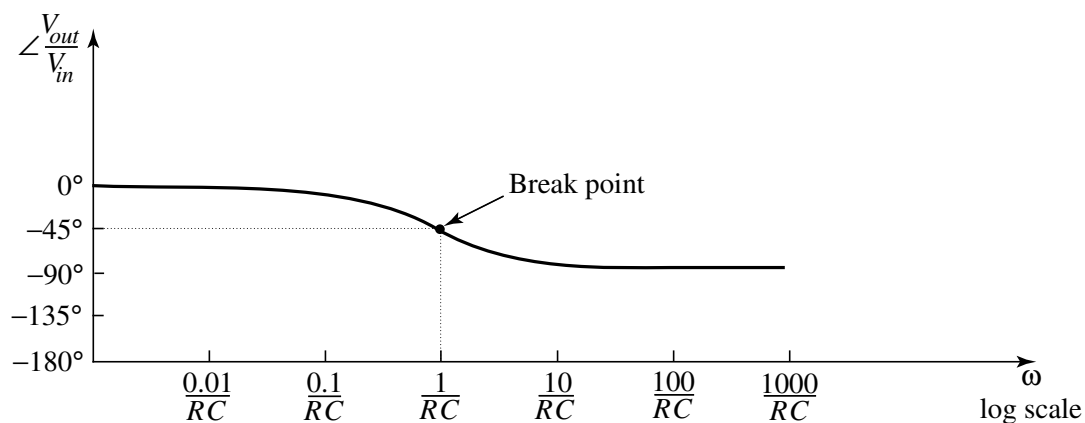

- Transition region extends from  $\omega_0 / 10$  to  $10 \omega_0$
- At  $\omega_0$  Phase =  $-45^\circ$

Review of Frequency Domain Analysis [Chap 10.1](#)

## II. Small Signal Models for Frequency Response

### Bipolar Transistor

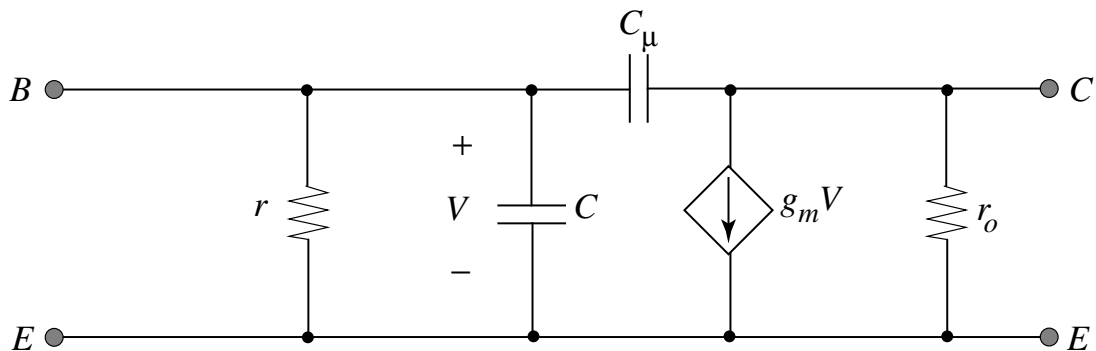

### MOS Transistor - $V_{SB} = 0$

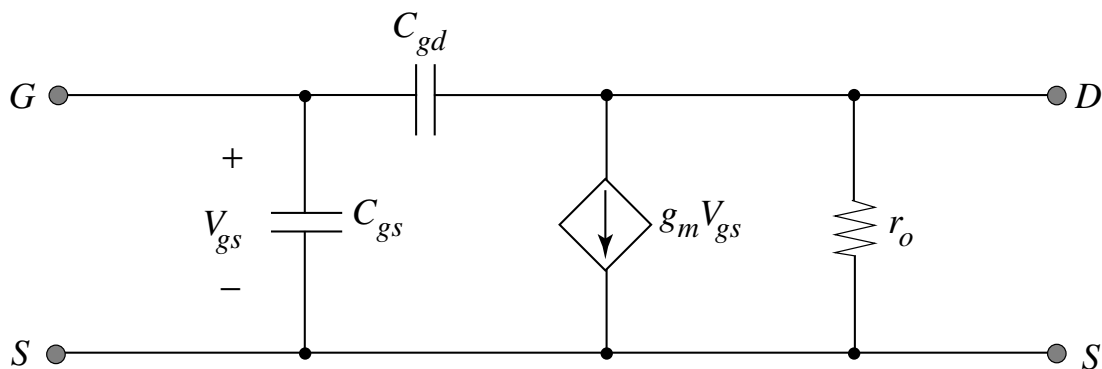

- Replace  $C_{gs}$  for  $C_\pi$
- Replace  $C_{gd}$  for  $C_\mu$
- Let  $r_\pi \rightarrow \infty$

# III. Frequency Response of Intrinsic CE Current Amplifier

$$R_S \rightarrow \infty \text{ \& } R_L = 0$$

Circuit analysis - Short Circuit Current Gain  $I_o/I_{in}$

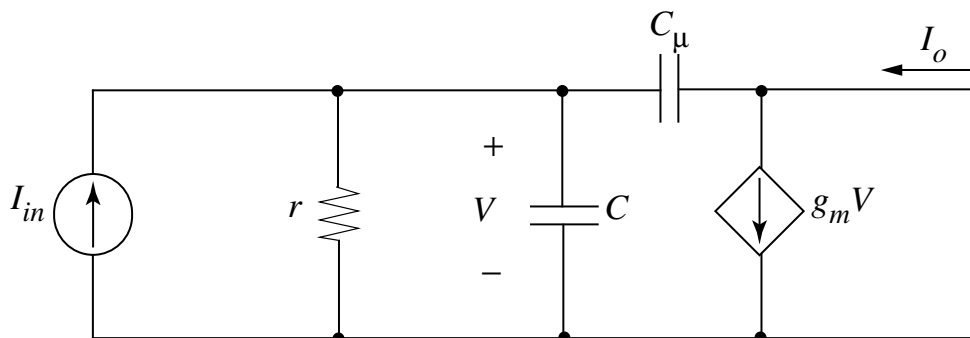

- KCL at the output node:

$$I_o = g_m V_\pi - V_\pi j \omega C_\mu$$

- KCL at the input node:

$$I_{in} = \frac{V_\pi}{Z_\pi} + V_\pi j \omega C_\mu \quad \text{where} \quad Z_\pi = r_\pi \parallel \left( \frac{1}{j \omega C_\pi} \right)$$

- After Algebra

$$\frac{I_o}{I_{in}} = \frac{g_m r_\pi \left( 1 - \frac{j \omega C_\mu}{g_m} \right)}{1 + j \omega r_\pi (C_\pi + C_\mu)} = \frac{\beta_o \left( 1 - \frac{j \omega C_\mu}{g_m} \right)}{1 + j \omega r_\pi (C_\pi + C_\mu)} = \beta_o \left[ \frac{1 - j \frac{\omega}{\omega_z}}{1 + j \frac{\omega}{\omega_p}} \right]$$

$$\omega_z = \frac{g_m}{C_\mu} \qquad \omega_p = \frac{1}{r_\pi (C_\pi + C_\mu)}$$

## Bode Plot of Short-Circuit Current Gain

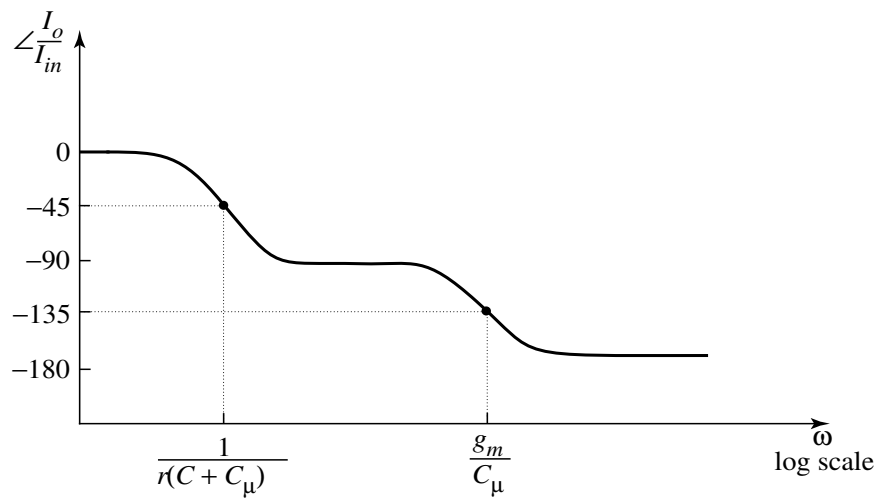
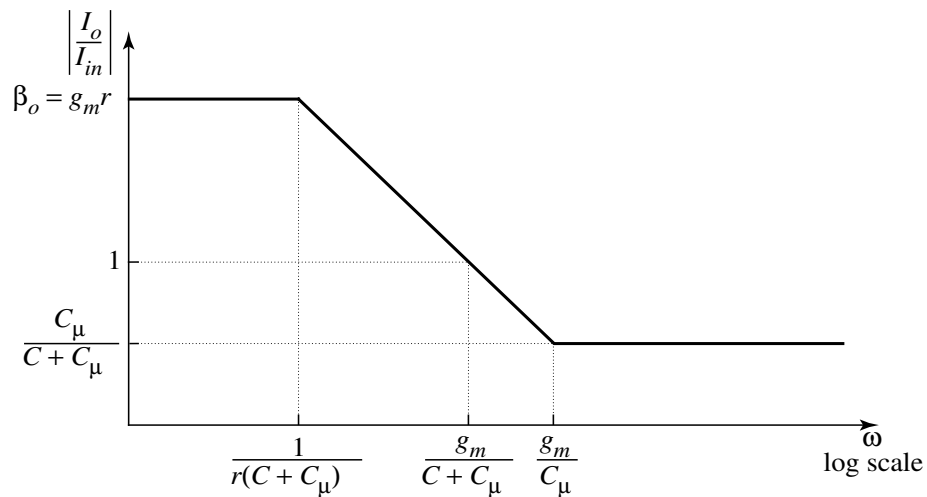

- Frequency at which current gain is reduced to 0 dB is defined at  $f_T$ :

$$f_T = \left( \frac{1}{2\pi} \right) \frac{g_m}{(C_\pi + C_\mu)}$$

## Gain-Bandwidth Product

- When we increase  $\beta_o$  we increase  $r_\pi$  BUT we decrease the pole frequency---> Unity Gain Frequency remains the same

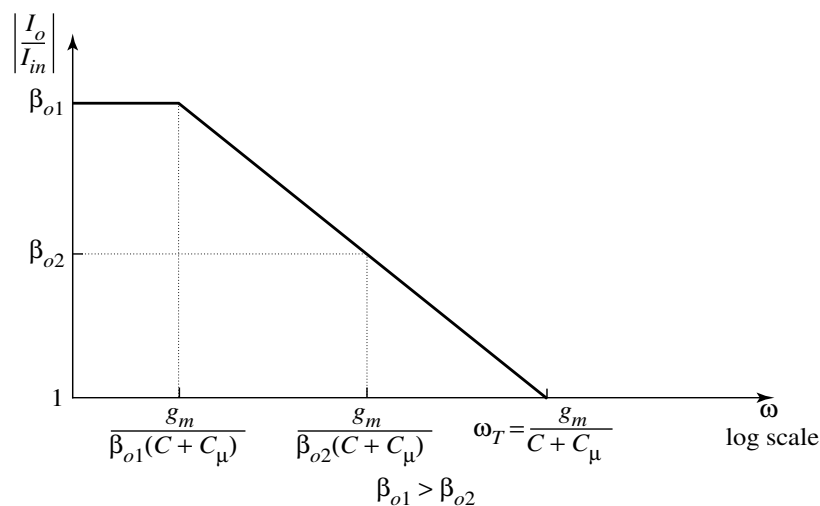

### Examine how transistor parameters affect $\omega_T$

- Recall

$$C_\pi = C_{je} + g_m \tau_F$$

- The unity gain frequency is

$$\omega_T = \frac{I_C / V_{th}}{(I_C / V_{th})\tau_F + C_{je} + C_\mu}$$



$$\omega_T = \frac{I_C / V_{th}}{(I_C / V_{th})\tau_F + C_{je} + C_{\mu}}$$

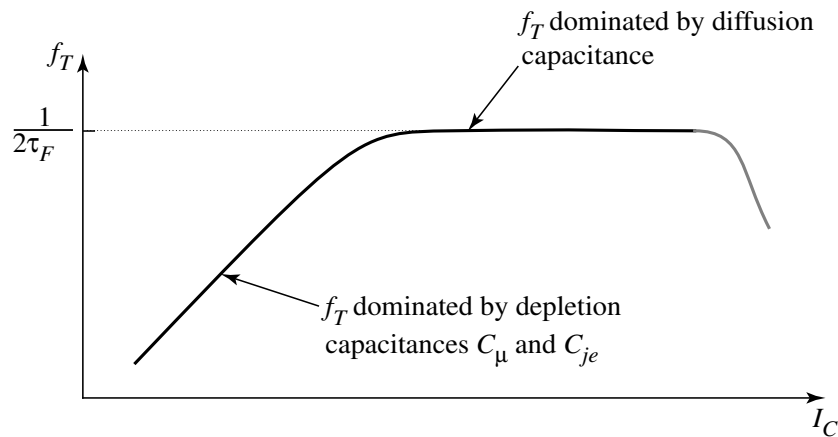

- At low collector current  $f_T$  is dominated by depletion capacitances at the base-emitter and base-collector junctions
- As the current increases the diffusion capacitance,  $g_m \tau_F$ , becomes dominant
- Fundamental Limit for the frequency response of a bipolar transistor is set by

$$\tau_F = \frac{W_B^2}{2 D_{n,p}}$$

### To Increase $f_T$

- High Current - Diffusion capacitance limited - Shrink basewidth
- Low Current - Depletion capacitance limited - Shrink emitter area and collector area - (geometries)

MIT OpenCourseWare  
<http://ocw.mit.edu>

6.012 Microelectronic Devices and Circuits  
Spring 2009

For information about citing these materials or our Terms of Use, visit: <http://ocw.mit.edu/terms>.